

Ground catchers

SABO



<https://www.locinox.com/en-gb/gate-hardware/accessories-for-gates/ground-catchers/p00006490>

Strong surface mounted ground stop for double wing gates. Drop bolts with a maximum axle of $\varnothing 20$ mm are the perfect fit.

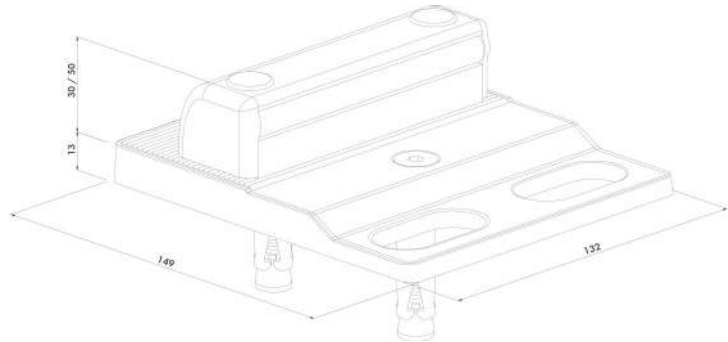

TECHNICAL SPECIFICATIONS

Materials Main Part(s)	Anodised Aluminium Glass Fibre Reinforced Polyamide
Hours of Salt Spray Testing	500
Years of Warranty	3